

Dome Storage/Drying Rack for Convection Domes Model #CR3DR104

Aladdin Temp-Rite's Dome Storage/Drying Racks are designed to dry and store our Convect-Rite Advance system domes thoroughly. Ensuring optimal hygiene and performance, the rack provides convenient storage and effortless transportation for these essential components. Crafted from durable 1" (2 cm) stainless-steel tubing, the rack features four stainless steel wire forms designed to support the domes securely. Equipped with four swivel casters, including two with locking brakes, the unit ensures both mobility and stability in any food service environment.

Standard Features

Design/Construction

- 104 dome capacity, 24 per level.
- Compatible with both 8" (20 cm) and 9" (22 cm) Aladdin High Heat or Clear Dimensions convection domes for versatility.
- Equipped with two locking casters and two swivel casters, each with a 5" (12 cm) diameter, for mobility and stability.
- Features four stainless steel wire forms.

Durability

- Constructed with durable 1" (2 cm) stainless steel tubing for longevity.
- Built with robust-welded frame construction to ensure durability.
- Offers exceptional stability during transportation, ensuring the safety of stored components.

Ease of Use

- Lightweight design enables easy transportation.
- Wire forms are easily detachable for convenience and make for easy cleaning.
- Facilitates effortless removal of domes during tray assembly, enhancing efficiency.



Dome Storage/Drying Rack for Convection Domes

Model #CR3DR104

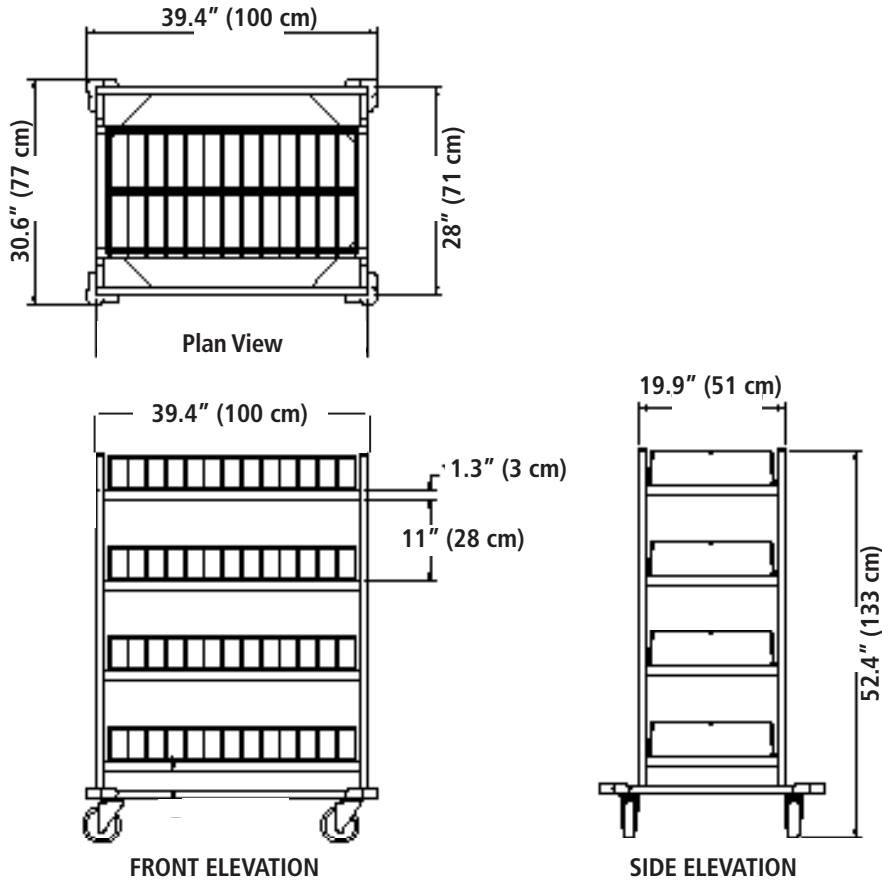

Model Number	Description	Capacity	Length	Width	Height	Height when Loaded	Frame Weight	Weight	Shipping Weight
<input type="checkbox"/> CR3DR104	Double storage rack	104 domes	39.4" (100 cm)	30.6" (77 cm)	52.4" (133 cm)	57.0" (145 cm)	58 lbs (26 kg)	88 lbs (39 kg)	120 lbs (54 kg)

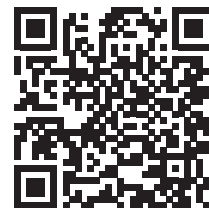

FOR SERVICE AND WARRANTY INFORMATION

CR Rack:
1 YEAR, Parts
90 DAYS, Labor

Visit aladdintemprite.com/patents for patent information.
250 E. Main St. | Hendersonville, TN 37075 | Customer Service: 800.888.8018 | Tech Service: 800.888.5426 | Fax: 888.812.9956 | aladdintemprite.com
©2024 Aladdin Temp-Rite.® All rights reserved. Note: Specifications are subject to change without notice.



S240423CR3D104 REV 1